

PHYS 115
Spring 2007

Exam 1

March 5, 2007

Read each question carefully and be sure to answer all parts. Include diagrams, personal observations and examples, and write clearly so that all work can be read. Be sure your name appears on each page. If you need more space, continue on the back of the same page on which the question is printed

1) **(10 points)** Describe to a person who's never taken this class what conditions are necessary to make a light bulb light. You may use pictures if you need to.

2) (10 points) Consider the circuit shown below. How bright are the bulbs A,B,C? How much current flows at the points 1,2,3? You can express your answers in terms of “battery equivalents”, i.e. the equivalent brightness/current for one bulb in series with one battery.

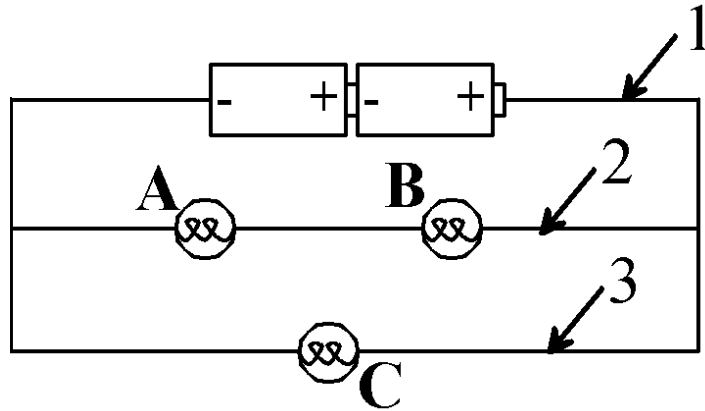

3) (10 points) For the circuit above, explain in words why you answered the way you did regarding the brightness of bulbs and the size of the currents. Relate your answer to one of the models we developed in class (e.g. blood, train, etc.). In the model, what is the battery or batteries? the wires? the light bulb(s)? the voltage? the current?

4) (10 points) For the four circuits below, what will the voltmeter read? Express your answer in volts. For each drawing, mark with a “+” sign the side of the voltmeter that would need to be positive (red) in order to get a positive reading, if applicable.

1) V=	1)		2)	
2) V=				
3) V=	3)		4)	
4) V=				

5) (10 points) For the circuit above, explain in words why you answered the way you did regarding the voltage. Relate your answer to one of the models we developed in class (e.g. blood, train, etc.). Explain what the voltmeter is measuring in this model, and why you get the readings of the voltage in the problem above, and how you chose the positive side of the voltmeter.

Name _____

6) **(10 points)** Do you think the light bulbs in your house are wired in series or parallel? Why? Cite examples from our experiments and from your experiences with light bulbs in your own house and describe *in detail* how the results of the experiments and your experiences support your answer. Suppose you have three light bulbs in your house, and three switches (one for each bulb). Draw a circuit with three light bulbs and three switches, with a battery for power, which might work like the light bulbs and switches in your house.

(40 points) Lab Practical - an authentic assessment to be carried out by your group. 40 minutes

On your table, you'll find a voltmeter, and ammeter, a power supply, some wires, and the resistor card that you have used already in class. Your job will be to measure the how current and voltage are related for two resistors on the card wired **in parallel**.

A. **(10 points)** With the power supply off, and the voltage knob turned to zero, wire the power supply, the two resistors (use the **green/brown/black/gold** and **orange/white/black/gold** resistors), the voltmeter, and the ammeter in a circuit such that the two resistors are in parallel, and the voltmeter will measure the voltage across the two resistors, and the ammeter will measure the total current from the power supply. Your instructor will write comments here regarding whether you did this correctly or not.

B. Turn on the power supply on. Use your circuit to measure the relationship between current and voltage for the **two resistors wired in parallel**.

C. Measure the current as a function of voltage for **each of the two resistors alone**.

D. **(10 points)** Make a graph of your data from B and C (all data on one plot), print it out, and attach it to the test. Make sure to label everything that should be labeled!

E. (10 points) Write down equations for:

(1) The current as a function of voltage for the **green-brown-black-gold** resistor.

(2) The current as a function of voltage for the **orange-white-black-gold** resistor.

(3) The current as a function of voltage for the **two resistors in parallel**.

Make sure to give the units for each quantity you use in your equations.

Name _____

F. **(10 points)** What do the numbers (e.g. slope and/or intercept) in the equations mean? How do these numbers for the parallel combination of resistors compare to the numbers for the individual resistors? Why? Do the two resistors in parallel act like a resistor? If so, what is the resistance? If not, why not?